

Installation Statement:

1. Before installation, carefully read the manual and operate according to the content of the manual;
2. Qualified electricians shall install and confirm the power off before installation or maintenance;
3. Suitable for indoor installation and use (not suitable for humid environments);
- 4. It is not allowed to directly connect to the mains 220V, and the power supply of the lighting fixtures is 24VDC;**
5. Suitable for WAC MT1M/MT2M/MT3M series tracks;
6. The light source of this lamp is non replaceable, and once it needs to be replaced (such as at the end of the lamp's lifespan), the entire lamp should be replaced;
7. Keep this manual properly for future use.

Installation of lighting fixtures:

1. Before assembly, ensure that the locking knobs at both ends of the AD box are in the "Unlock" position State, as shown in the following figure

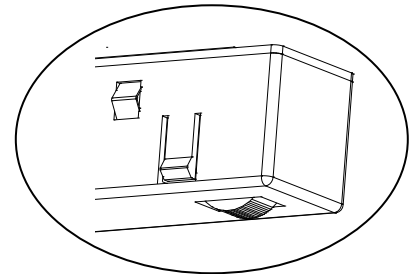
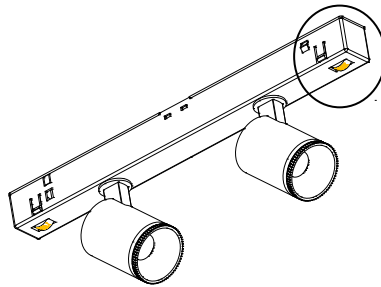
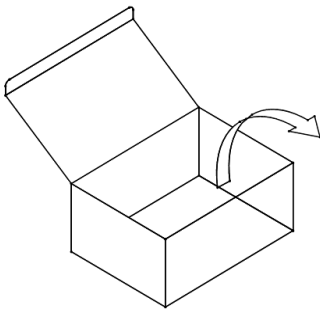

When the knob striped surface is in the "Unlock" state

2. Installation and disassembly of lighting fixtures

Licensed by "WAC" trademark holder - WAC LIGHTING, USA

Chinese Marketing Headquarters

: WAC Lighting (Shanghai) Co, Ltd.

Address

: 14, Lane 299, Bi Sheng Road, Shanghai 201204, China

China factory

: Manufactured WAC Lighting (Dongguan) Co, Ltd.

Address

: 390, Qingfeng Road, Qingxi Town, Dngguan, Guangdong. Postal code: 523653

Lamp adjustment:

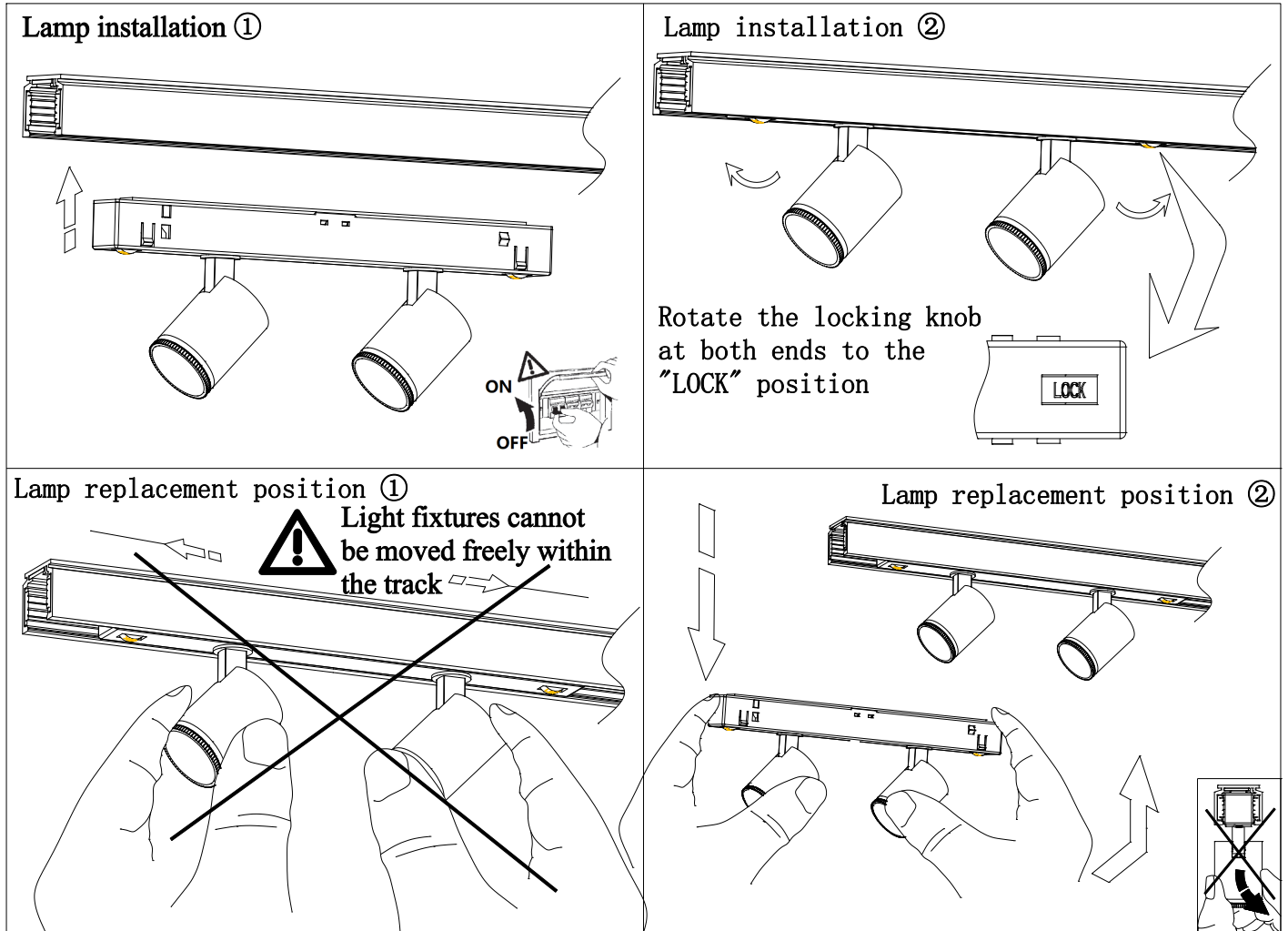

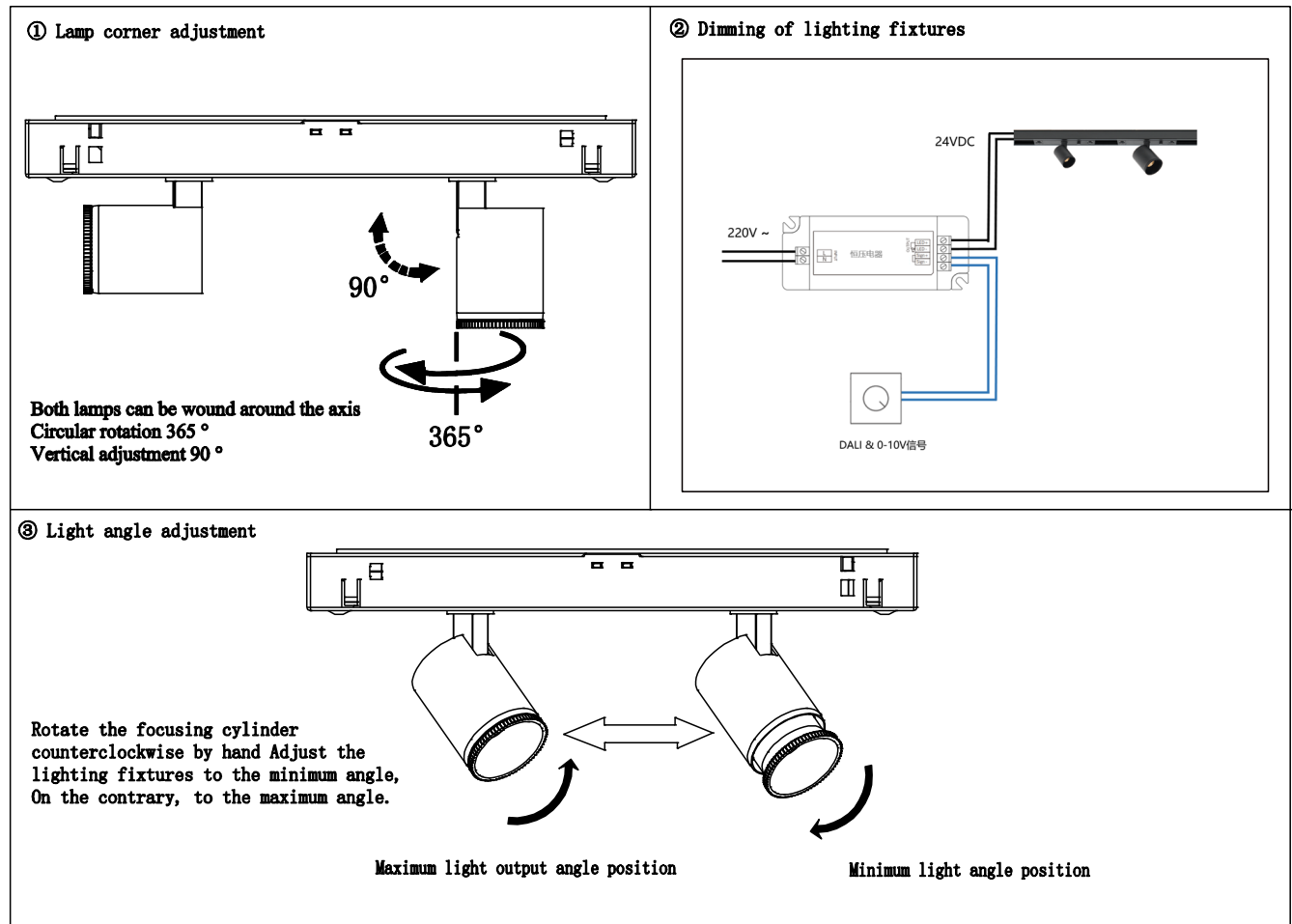

MLE incoming terminal wiring:

The internal drive of the lamp has been equipped with positive and negative pole anti reverse connection circuit protection, so there is no need to distinguish between positive and negative poles when wiring the incoming terminal.

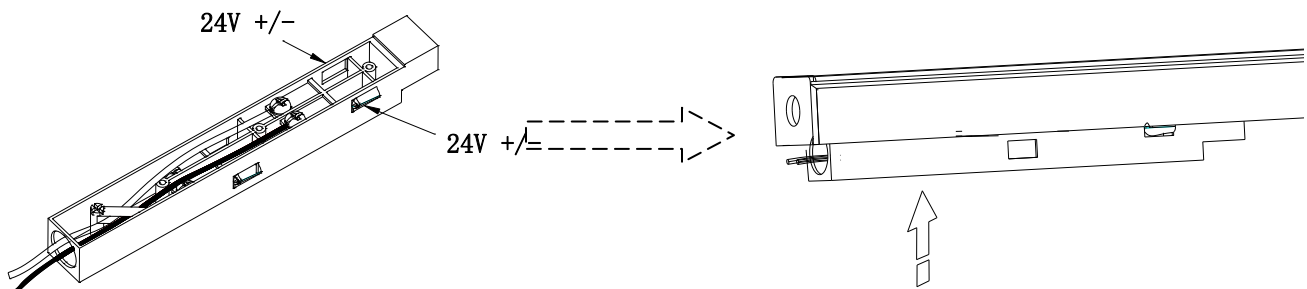

After wiring the incoming terminal, embed it into the track