

## Installation Declaration:

- 1、Please read the instructions carefully before installation;
- 2、Please professional electrician installation;
- 3、To avoid the risk of electric shock, please make sure to turn off the power supply before installation and maintenance;
- 4、The installation of lamps and lanterns should follow the corresponding local laws and regulations;
- 5、Suitable for indoor and outdoor installation;
- 6、Keep the manual for reference. .

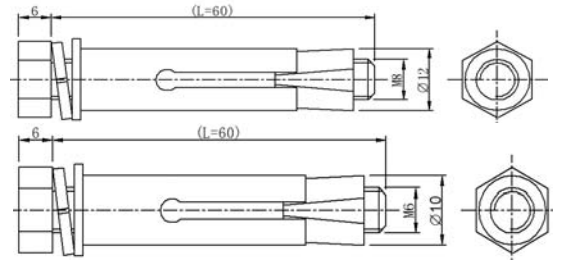

M6/M8 screw size reference diagram

**Note: all installation and replacement or maintenance operation before the need to cut off the power**

## Installation of lamps and lanterns:

一、Installation of lamps and lanterns:

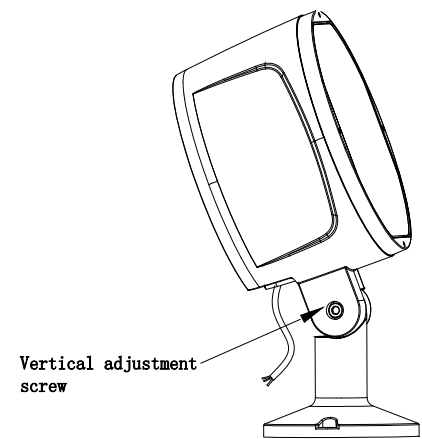
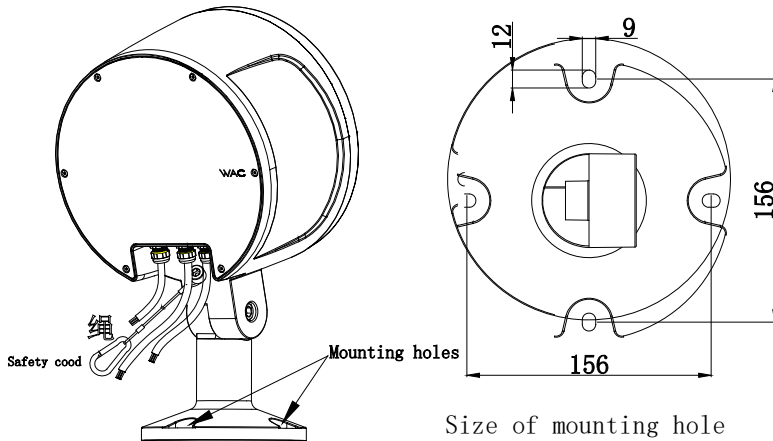

1、Secure the luminaire with a suitable expansion bolt (M6 or m8) through the illustrated mounting hole (After the installation of lamps and lanterns find a fixed place to fix the safety rope)

2、LAMP illumination angle adjustment: with Hexagon Wrench adjust screw, turn the lamp to the required angle can be (vertical direction before 30 degrees, after 90 degrees adjustable)

二、Wiring and control adjustment

3、Power input for: AC220V, product for non-dimming version wiring schematic, Power Input Line label affixed logo: Fire Line L, Zero Line N, ground wire ⊕

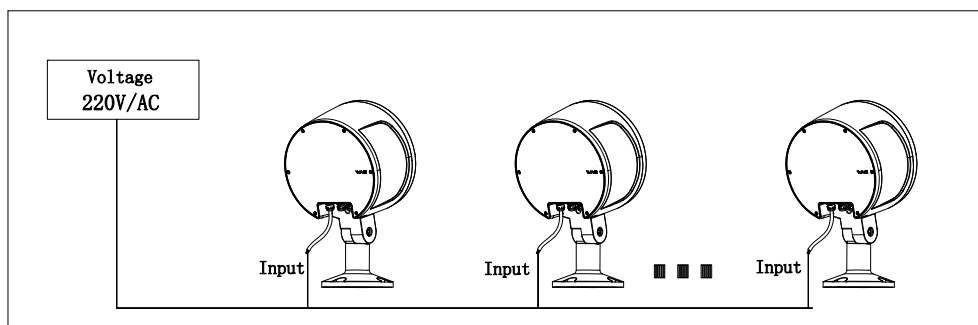

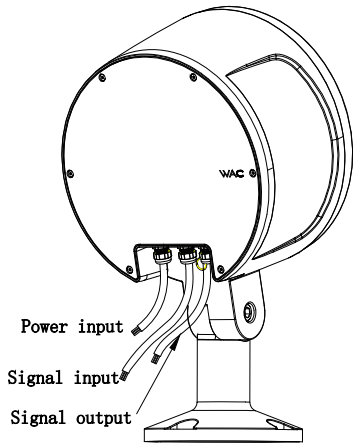

DMX512 Signal Wire labeling  
 Yellow-green Wire: Gnd Ground wire  
 Red Wire: DMX Signal input+  
 Black Wire: DMX Signal input-

4、Power input: AC220V, product for DMX512 dimming lamps wiring:  
 Note:  
 a:Connect the power input wire of each luminaire, the connection of the wire should be waterproof;  
 b:Lamps and lanterns can be connected together by signal lines, each DMX signal amplifier contains lamps, recommended no more than 10 is appropriate;

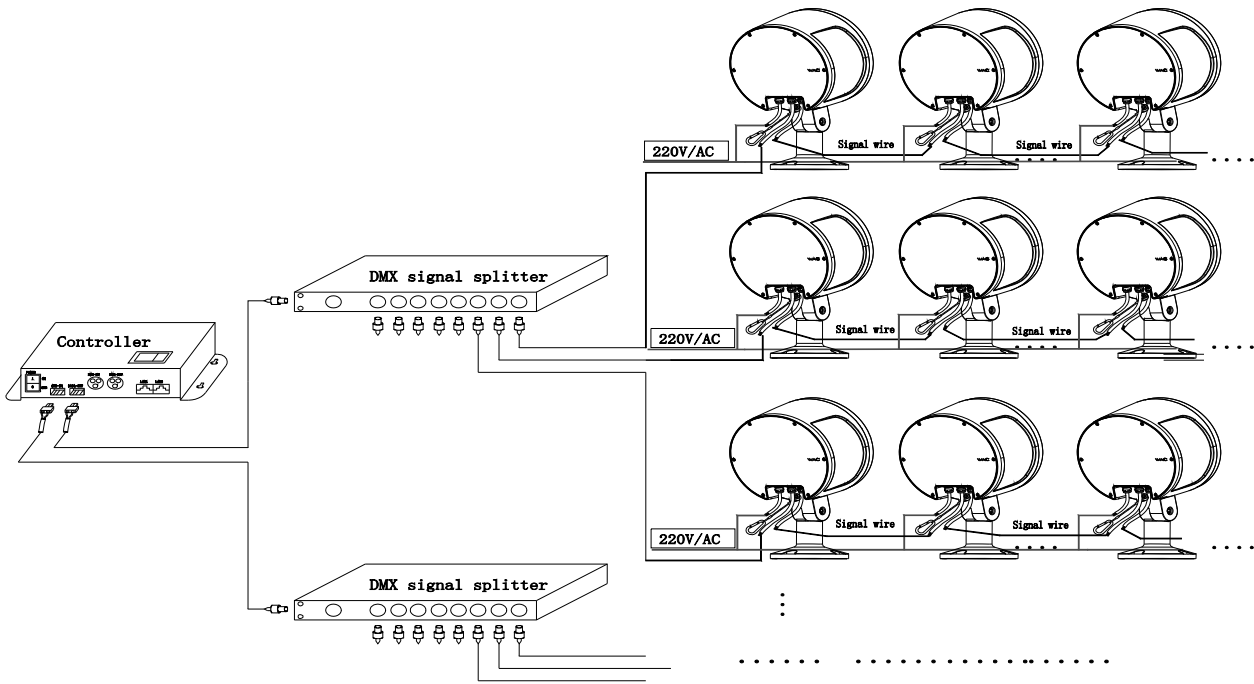

**Note:**

1. Cable cable is not included, need to use waterproof 3-core cable, cable diameter of  $\phi 5-\phi 9\text{mm}$  (The mark on the connector: firewire L, Zero Wire N, ground wire  $\oplus$ );
2. The glass shield must be replaced if damage is found during installation;
3. When the glass cover is damaged and replaced, the guest can only use the glass cover provided by our company.

Licensed by "WAC" trademark holder - WAC LIGHTING, USA  
 Chinese Marketing Headquarters : WAC Lighting (Shanghai) Co, Ltd.  
 Address : 14,Lane 299, Bi Sheng Road, Shanghai 201204,China  
 China factory : Manufactured WAC Lighting (Dongguan) Co, Ltd.  
 Address : 390, Qingfeng Road, Qingxi Town, Dngguan, Guangdong. Postal code: 523653