

**Product model:**

This installation manual is applicable to the ELC303-03 series, ELC305-06 series and ELC310-12 series of LED outdoor hard strip lights.

**Installation Precautions:**

1. Please read through the Instructions before installation.
2. The product should be installed by a professional electrician.
3. Make sure the power supply is cut off before installation and maintenance, to avoid the risk of electric shock.
4. Before installing the lighting fixtures, please confirm that the installation surface is firm and reliable to prevent the fixtures from falling.
5. Please keep this Instruction properly for future reference.

**Installation method and steps:**

1. The installation method of this line light is to first fix the U-shaped stainless steel bracket; A light strip requires 2 brackets; The fixing holes of the bracket are shown in Figure 1; Note: Self tapping screws and plastic geckos are to be provided by the construction party;
2. The light strip is inserted through the opening of the U-shaped bracket, as shown in Figure 3; After being clamped in place, as shown in Figure 4, there is a hook that pulls outward and is not easy to fall off;
3. Install adjacent light strips and connect them first before inserting them into the U-shaped bracket; As shown in Figure 5, the lighting fixture has signal input and output directions. Please follow the instructions on the label on the wire for wiring.

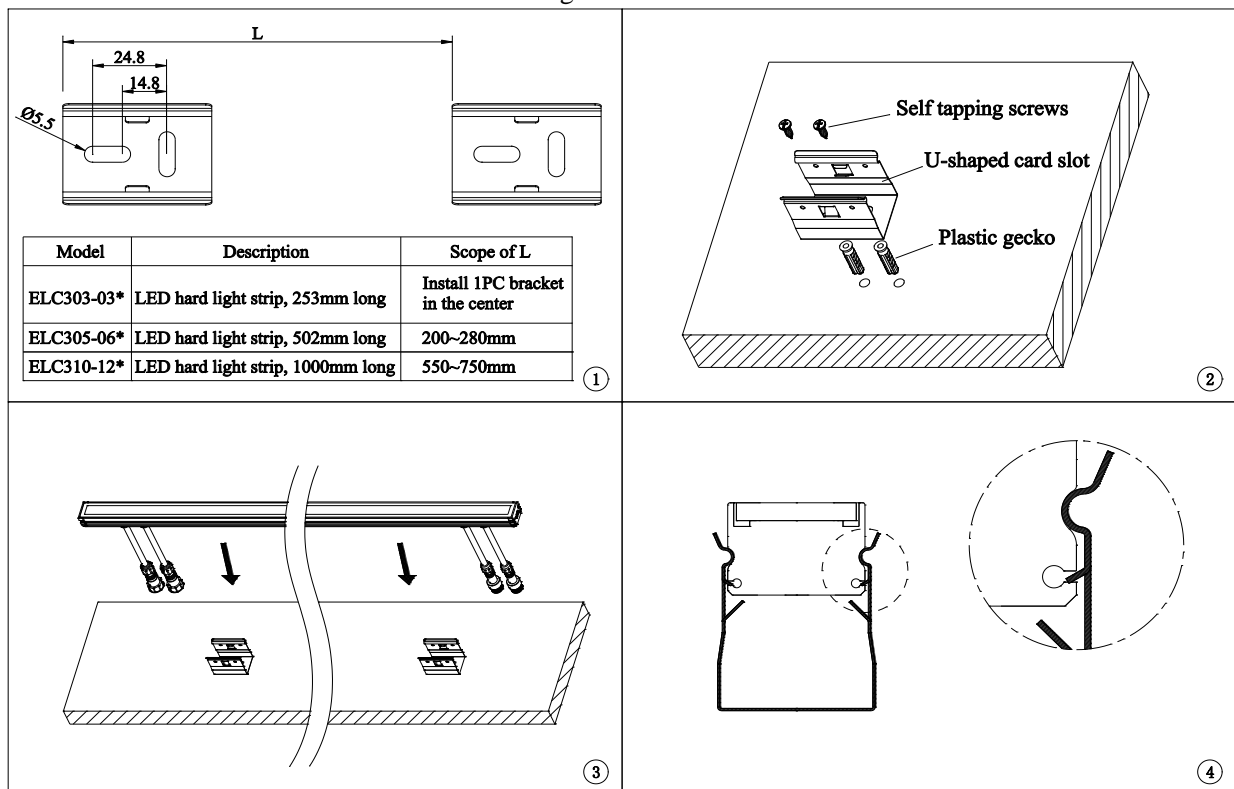

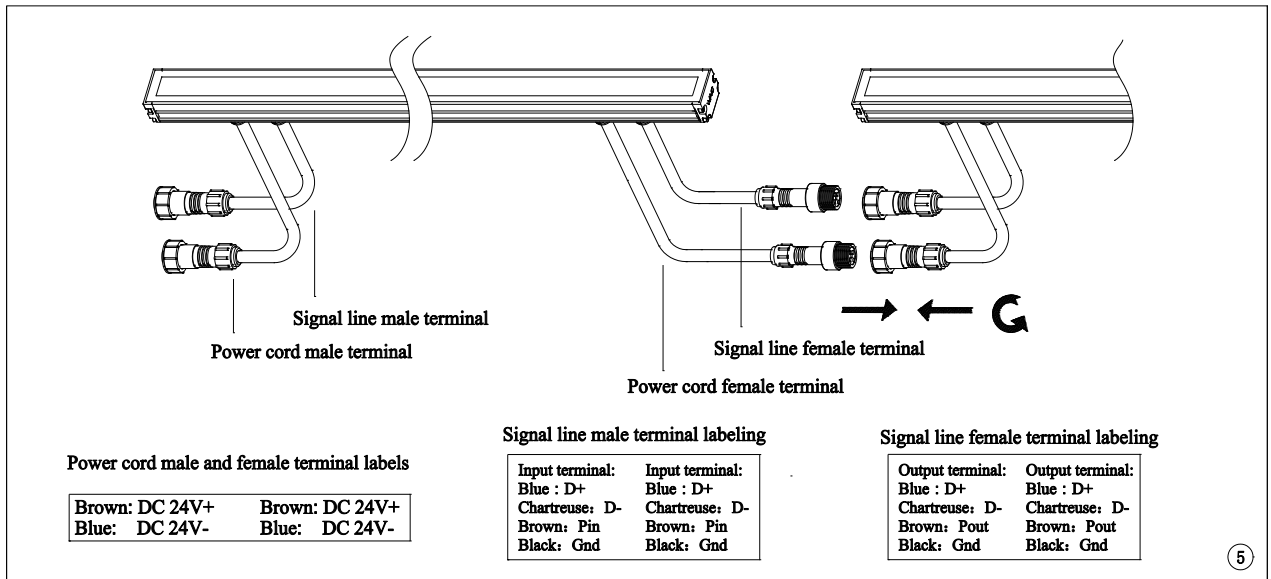

4. The wiring of the lighting fixtures is shown in the following schematic diagram:

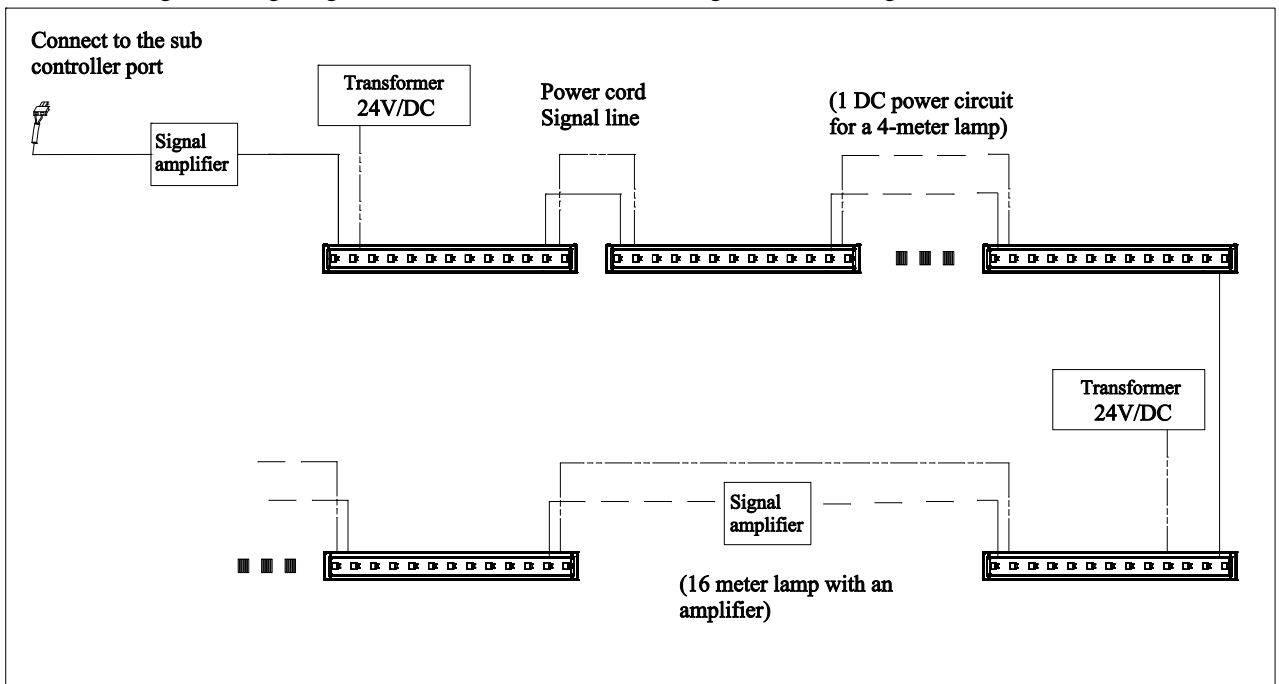

**Note:**

- \* The connection of power and signal lines should be made using the waterproof connector wire provided by WAC.
- \* Suggest a transformer power circuit for 4-6 meter lamps
- \* Before connecting the lighting fixtures to the sub control port, a signal amplifier was added; Then, add a signal amplifier every 16 meters of lighting equipment.
- \* The usage of the main controller and sub controller can be found in the manual of the main controller and sub controller.